

IMF PART NO.	1901A0202BFC
PALMER PART NO.	700000900B
DESCRIPTION	BLADE ASSEMBLY GIW 40

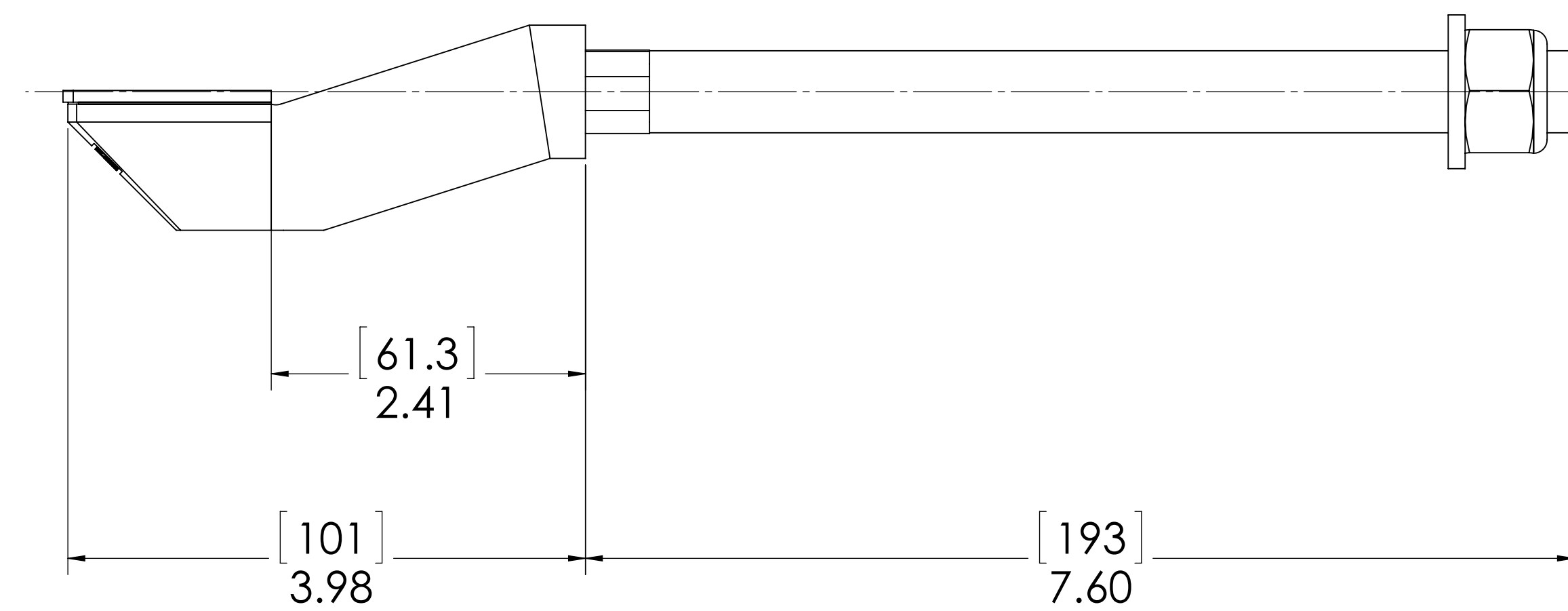
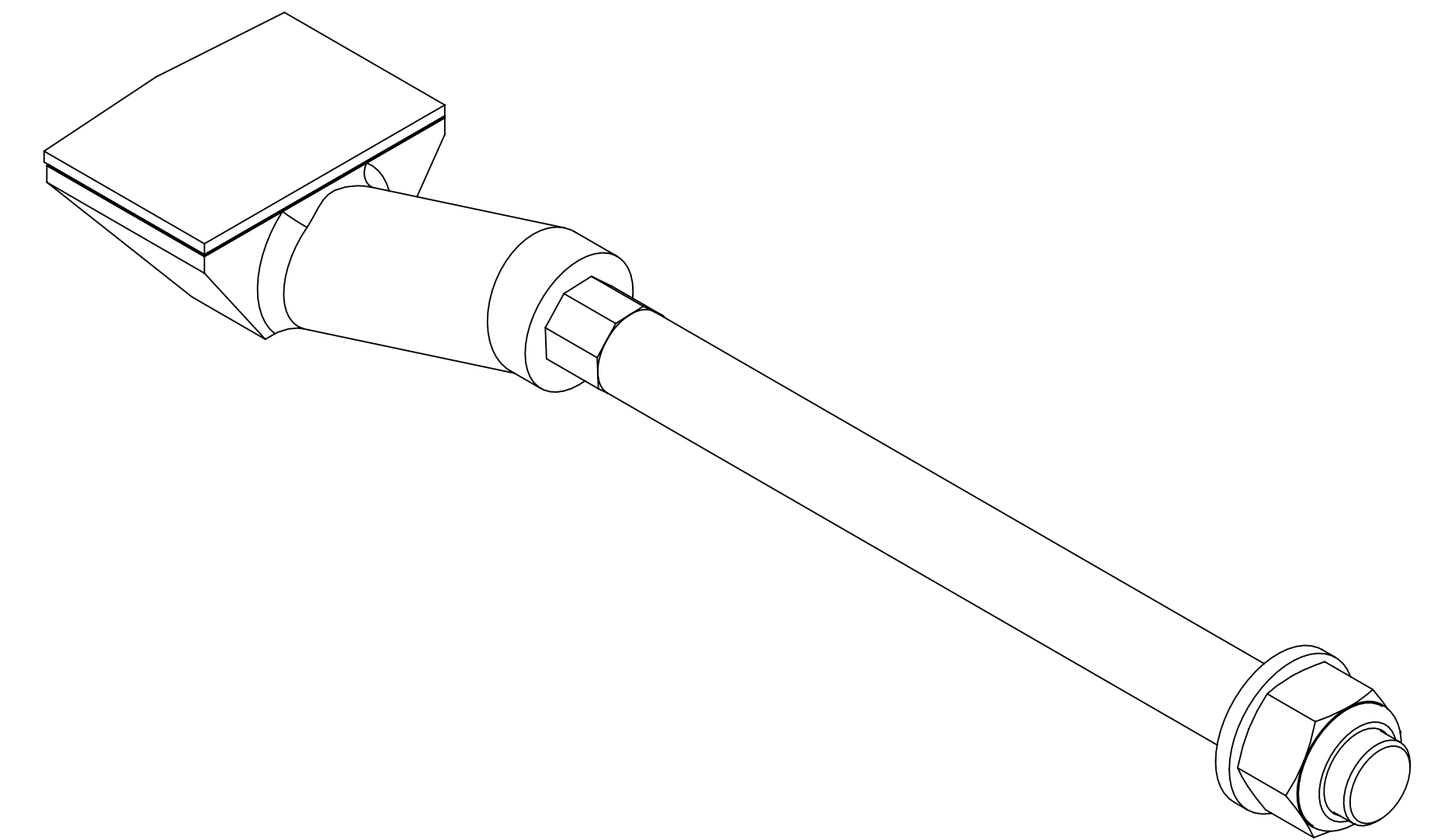
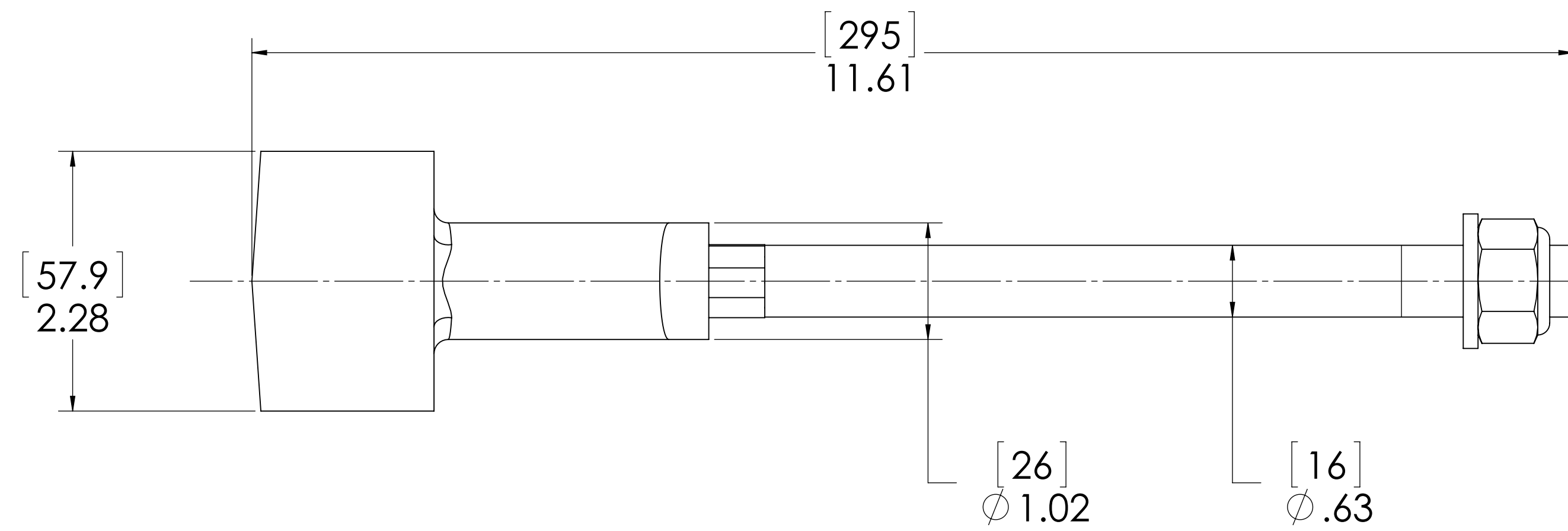

NOTE: UNITS IN [MM] INCHES

<b>PROPRIETARY AND CONFIDENTIAL</b> - THE INFORMATION CONTAINED IN THIS DRAWING IS THE SOLE PROPERTY OF PALMER MANUFACTURING. ANY REPRODUCTION IN PART OR AS A WHOLE WITHOUT THE WRITTEN PERMISSION OF PALMER MANUFACTURING IS STRICTLY PROHIBITED.		DRAWN: R.J. 7/27/16 APPROVED: [Signature]		NAME: [Blank] DATE: [Blank]	
DIMENSIONS ARE IN INCHES TOLERANCES: FRACTIONAL: ±1/16 ANGULAR: MACH ±1 BEND ±1 ONE PLACE DECIMAL ±.150 TWO PLACE DECIMAL ±.030 THREE PLACE DECIMAL ±.005		MATERIAL: [Blank] FINISH: [Blank] WEIGHT: [Blank]		CUSTOMER: [Blank]	
PART NO. 01127300A		TITLE <b>BLADE ASSEMBLY GIW 40</b>		SIZE DWG. NO. REV <b>D 700000900B 0</b>	
SCALE: 1:1 DO NOT SCALE		SHEET: 1 OF 1		18 BECHTEL AVE SPRINGFIELD, OH 45504 U.S.A. (937) 523-4339 (800) 457-5456 <b>PALMER MANUFACTURING &amp; SUPPLY, INC.</b>	